

DISTRIBUTION STATEMENT A. Approved for public release; distribution is unlimited.
 This military standard is approved for use by all Departments and Agencies of the Department of Defense.
 Selection for all new engineering and design applications and for repetitive use shall be made from this document when applicable.

REVIEWER ACTIVITIES:
 AIR FORCE-82
 DLA-1S

USER ACTIVITIES:
 ARMY-CR, MI

PA NAVY-AS INTERNATIONAL TITLE
 Other Cust ARMY-AV
 AIR FORCE-11
 PROCUREMENT SPECIFICATION SUPERSEDES
 MIL-N-25027 NAS 697

(F) ENTIRE STANDARD REVISED
 NUT, SELF-LOCKING, PLATE, TWO LUG,
 REDUCED RIVET SPACING, LOW HEIGHT,
 STEEL, 125 KSI Ft_u, 450° F

MILITARY STANDARD
MS21069

PAGE 1 OF 2

CONFIGURATION OF NUT OPTIONAL WITHIN THE LIMITATIONS IMPOSED BY DIMENSIONS AND REQUIREMENTS SPECIFIED HEREIN

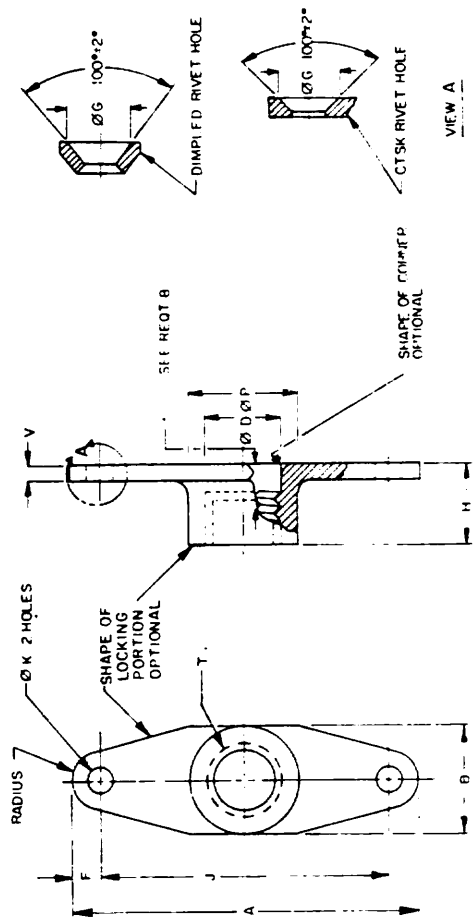

TABLE 1. DASH NUMBERS AND DIMENSIONS

DASH NUMBERS	PLAIN RIVET HOLES		COMBINATION OR DIMPLD RIVET HOLES		T THREAD SIZES	A MAX	Ø D MIN	F MIN	Ø G MIN	H 1/ MAX	J 2/ MIN	Ø K 3/ MAX	V MAX	AXIAL STRENGTH LBS./MIN	Ø P MAX
	NON-DRY FILM LUBRICANT	DRY FILM LUBRICANT	NON-DRY FILM LUBRICANT	DRY FILM LUBRICANT											
-02					.086-56 UNJC-3H	.410	.162	.140	.071	.110	.250	.066	.130	440	.075
-03					.089-48 UNJC-3H	.425	.184	.140	.071	.125	.265	.066	.143	500	.08
-04					.117-40 UNJC-3H	.630	.260	.140	.089	.143	.406	.098	.166	750	.11
-06					.138-32 UNJC-3H	.661	.265	.195	.089	.171	.437	.098	.206	1,130	.14
-08					.164-32 UNJC-3H	.692	.297	.230	.100	.250	.469	.098	.248	1,720	.18
-3					.190-32 UNJF-3H	.724	.328	.298	.100	.250	.500	.098	.274	2,460	.26
-4					.250-28 UNJF-3H	.786	.414	.360	.100	.281	.562	.098	.344	4,580	.40
-5					.3125-24 UNJF-3H	1.006	.505	.475	.125	.328	.718	.130	.417	7,390	.77
-6					.375-24 UNJF-3H	1.116	.614	.580	.125	.344	.828	.130	.505	11,450	1.06

1/ MINIMUM "H" NOT SPECIFIED, LIMITED ONLY BY STRENGTH REQUIREMENTS OF SPECIFICATION.
 2/ CENTER OF THE DIMPLD HOLE SHALL NOT DEVIATE IN ANY DIRECTION FROM THE CENTER OF THE PLATE NUT AS DETERMINED BY THE RIVET HOLES BY MORE THAN .005.
 3/ DIMPLD RIVET HOLE TOLERANCE FOR Ø "K" IS +.015 -.000.
 4/ SPACE WILL NOT PERMIT COUNTERSINK.

APPROVED 6 APR 64 REVISED 30 SEP 87

REQUIREMENTS:

- MATERIAL:** CARBON STEEL, COMPOSITIONS 1035 (UNS G10350), 1040 (UNS G10400 AND 1050 (UNS G10500), IN ACCORDANCE WITH QQ-S-635; 1042 (UNS G10420) IN ACCORDANCE WITH ASTM A29. ALLOY STEEL, GRADES 4130 (UNS G41300), 4340 (UNS G43400) AND 8740 (UNS G87400) IN ACCORDANCE WITH ASTM A29.
- FINISH:** CADMIUM PLATE IN ACCORDANCE WITH QQ-P-416 TYPE II, CLASS 3. FOR DRY FILM LUBRICATED NUTS, THE TYPE AND CLASS ARE OPTIONAL IF THE NUTS MEET THE SALT SPRAY REQUIREMENTS OF QQ-P-416 TYPE II.
- DIMENSIONING AND TOLERANCING:** DIMENSIONING AND TOLERANCING SHALL BE IN ACCORDANCE WITH ANSI Y14.5M.
- HARDNESS:** 49HRC, MAX.
- THREADS:** THREADS BEFORE LUBRICATION IN ACCORDANCE WITH MIL-S-8879.
- SURFACE TEXTURE:** SURFACE TEXTURE, UNLESS OTHERWISE SPECIFIED, SHALL NOT EXCEED 125 MICROINCHES, IN ACCORDANCE WITH ANSI B46.1.
- LUBRICANT:** DRY FILM LUBRICANT APPROVED IN ACCORDANCE WITH MIL-N-25027. NON-DRY FILM LUBRICANTS SHALL BE SOLUBLE IN THE CLEANER SPECIFIED IN MIL-S-8802.
- COUNTERBORE/COUNTERSINK:** ON SIZE .164 AND LARGER, THREAD RELIEF SHALL BE .062 MINIMUM; ON SIZE .138 AND SMALLER, COUNTERSINK TO "P" DIAMETER.
- PART NUMBER:** THE PART NUMBER SHALL CONSIST OF THE BASIC MS NUMBER FOLLOWED BY A DASH NUMBER FROM TABLE 1.

EXAMPLE: MS21069L4K

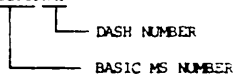

MS21069L4K INDICATES: NUT, SELF-LOCKING, PLATE, TWO LUG, REDUCED RIVET SPACING, LOW HEIGHT, STEEL; 125 KSI Ft_u, 450°F; .250-28 UNJF-3B; DRY FILM LUBRICATION; COUNTERSUNK OR DIMPLED HOLES.

NOTES:

- ALL DIMENSIONS ARE IN INCHES.
- IN THE EVENT OF A CONFLICT BETWEEN THE TEXT OF THIS STANDARD AND THE REFERENCES CITED HEREIN, THE TEXT OF THIS STANDARD SHALL TAKE PRECEDENCE.
- REFERENCED GOVERNMENT (OR NON-GOVERNMENT) DOCUMENTS OF THE ISSUE LISTED IN THAT ISSUE OF THE DEPARTMENT OF DEFENSE INDEX OF SPECIFICATIONS AND STANDARDS (DODISS) SPECIFIED IN THE SOLICITATION FORM A PART OF THIS STANDARD TO THE EXTENT SPECIFIED HEREIN.
- DESIGN AND USAGE LIMITATIONS: THESE NUTS ARE DESIGNED TO DEVELOP THE TENSILE STRENGTH OF BOLTS AND SCREWS WITH AN ULTIMATE TENSILE STRENGTH OF 125 KSI BASED ON THE CROSS SECTION AREA AT THE BASIC ROOT DIAMETER OF THE THREADS. THESE NUTS ARE DESIGNED TO BE USED ON 3A EXTERNAL THREADS. THESE NUTS SHALL BE USED IN ACCORDANCE WITH THE LIMITATIONS OF MS33588. ONLY NUTS FOR WHICH THERE ARE QUALIFIED PRODUCTS LISTED ON QPL 25027 SHALL BE USED.

INTERCHANGEABILITY RELATIONSHIP

MS21069 NUTS CAN UNIVERSALLY REPLACE NAS697 NUTS OF LIKE MATERIAL, THREAD SIZE, LUBRICANT (DRY FILM OR NON-DRY FILM LUBRICANT), AND FASTENING METHOD (PLAIN RIVET HOLES; DIMPLED OR COUNTERSUNK RIVET HOLES), BUT THESE NAS697 NUTS CANNOT UNIVERSALLY REPLACE MS21069 NUTS.

INTERCHANGEABILITY TABLE

CANCELLED PART NUMBERS	SUBSTITUTIVE PART NUMBERS	CANCELLED PART NUMBERS	SUBSTITUTIVE PART NUMBERS
NAS697X02	MS21069-02	NAS697X3K	MS21069-3K
NAS697A02	MS21069L02	NAS697A3K	MS21069L3K
NAS697X03	MS21069-03	NAS697X4	MS21069-4
NAS697A03	MS21069L03	NAS697A4	MS21069L4
NAS697X04L	MS21069-04	NAS697X4K	MS21069-4K
NAS697A04L	MS21069L04	NAS697A4K	MS21069L4K
NAS697X04LK	MS21069-04K	NAS697X5	MS21069-6
NAS697A04LK	MS21069L04K	NAS697A5	MS21069L6
NAS697X06L	MS21069-06	NAS697X5K	MS21069-6K
NAS697A06L	MS21069L06	NAS697A5K	MS21069L6K
NAS697X06LK	MS21069-06K	NAS697X6	MS21069-6
NAS697A06LK	MS21069L06K	NAS697A6	MS21069L6
NAS697X08	MS21069-08		
NAS697A08	MS21069L08		
NAS697X08K	MS21069-08K		
NAS697A08K	MS21069L08K		
NAS697X3	MS21069-3		
NAS697A3	MS21069L3		

P. A. NAVY-AS Other Cust ARMY-AV AIR FORCE-II	INTERNATIONAL INTEREST	TITLE NUT, SELF-LOCKING, PLATE, TWO LUG, REDUCED RIVET SPACING, LOW HEIGHT, STEEL, 125KSI Ft _u , 450°F	MILITARY STANDARD MS21069
PROCUREMENT SPECIFICATION MIL-N-25027	SUPERSEDES: NAS 697		PAGE 2 OF 2

DD FORM 1 MAY 63 672-1 (COORDINATED)

PREVIOUS EDITIONS OF THIS FORM ARE OBSOLETE

5310-1540

USER ACTIVITIES:
ARMY-CR, MI

REVIEWER ACTIVITIES:
AIR FORCE-82
DLA-IS

This military standard is approved for use by all Departments and Agencies of the Department of Defense. Selection for all new engineering and design applications and for repetitive use shall be made from this document when applicable.

APPROVED 6 APR 64 REVISED (F) FOR CHANGES SEE PAGES 1 AND 2