

CONFIGURATION OF NUT OPTIONAL WITHIN THE LIMITATIONS IMPOSED BY DIM'S, AND REQUIREMENTS AS SPECIFIED HEREIN.

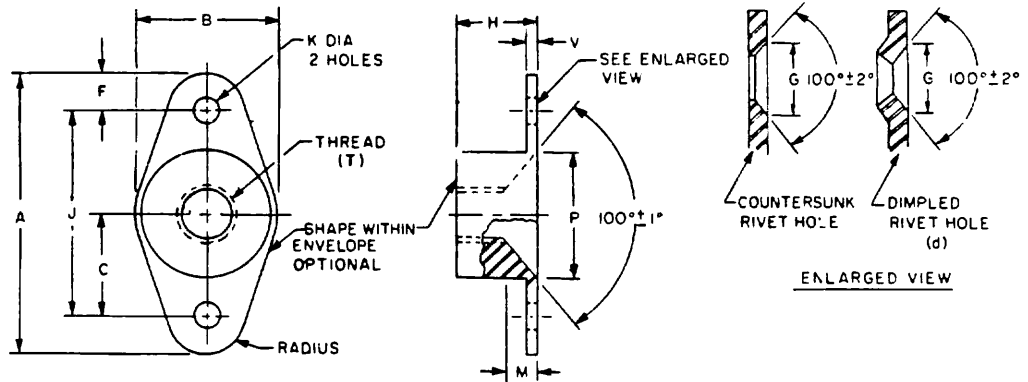

(T) THREAD SIZE	A		B		C ±.005	F MIN.	G DIA. ±.010	(b)	(c)	K DIA. +.005 -.000	M REF.	P DIA. ±.005	V MAT'L MAX.	AXIAL STRENGTH LBS. MIN.	WEIGHT LBS 100 MAX.
	MAX.	MIN.	MAX.	MIN.				H MAX.	J ±.002						
.1640-32 UNJC-3B	.948	.422	.360	.344	.100	.200	.272	.688	.096	.084	.365	.047	1,720	.39	
.1900-32 UNJF-3B	.948	.453	.406	.344	.100	.200	.281	.688	.098	.093	.411	.047	2,460	.41	
.2500-28 UNJF-3B	1.260	.619	.535	.500	.100	.200	.340	1.000	.098	.121	.540	.055	4,580	.88	
.3125-24 UNJF-3B	1.292	.766	.681	.500	.125	.230	.422	1.000	.130	.156	.686	.065	7,390	1.17	

- (a) THREADS BEFORE LUBRICATION PER MIL-S-8879.
- (b) MINIMUM "H" NOT SPECIFIED, LIMITED ONLY BY STRENGTH REQUIREMENTS.
- (c) CENTER OF THE TAPPED HOLE SHALL NOT DEVIATE IN ANY DIRECTION FROM THE CENTER OF THE PLATE NUT AS DETERMINED BY THE RIVET HOLES BY MORE THAN .005.
- (d) DIMPLED HOLE TOLERANCE FOR "K" IS +.015, -.000 AFTER FORMING.

- (E) MATERIAL: Carbon Steel UNS G10350 (AISI 1035)
UNS G10400 (AISI 1040)
UNS G10420 (AISI 1042)
UNS G10500 (AISI 1050)
Alloy Steel UNS G41300 (AISI 4130)
UNS G43400 (AISI 4340)
UNS G87400 (AISI 8740)

PLATING: CADMIUM PLATE IN ACCORDANCE WITH QQ-P-416, TYPE II, CLASS 2. FOR DRY FILM LUBRICATED NUTS, THE TYPE AND CLASS ARE OPTIONAL IF THE NUTS MEET THE SALT SPRAY REQUIREMENTS OF QQ-P-416.

- (E) HARDNESS: 49 HRC MAX
- (E) LUBRICANT: DRY FILM LUBRICANT APPROVED IN ACCORDANCE WITH MIL-N-25027. OTHER LUBRICANTS SOLUBLE IN THE CLEANER SPECIFIED IN MIL-S-7502.

DIMENSIONS IN INCHES

SURFACE ROUGHNESS IN ACCORDANCE WITH ANSI B46.1. UNLESS OTHERWISE SPECIFIED, THE SURFACE ROUGHNESS SHALL NOT EXCEED 125 MICRONS.

DESIGN AND USAGE LIMITATIONS: THESE NUTS ARE DESIGNED TO DEVELOP THE TENSILE STRENGTH OF BOLTS AND SCREWS WITH AN ULTIMATE TENSILE STRENGTH OF 125 KSI BASED ON A CROSS SECTIONAL AREA AT THE BASIC ROOT DIAMETER OF THE THREAD. THESE NUTS ARE DESIGNED TO BE USED ON 3A EXTERNAL THREADS. THESE NUTS SHALL BE USED IN ACCORDANCE WITH THE LIMITATIONS OF MS33588. ONLY NUTS FOR WHICH THERE ARE QUALIFIED PRODUCTS LISTED ON QPL 25027 SHALL BE USED.

IN THE EVENT OF A CONFLICT BETWEEN THE TEXT OF THIS STANDARD AND THE REFERENCES CITED HEREIN, THE TEXT OF THIS STANDARD SHALL TAKE PRECEDENCE.

- (E) REFERENCED GOVERNMENT (OR NON-GOVERNMENT) DOCUMENTS OF THE ISSUE LISTED IN THAT ISSUE OF THE DEPARTMENT OF DEFENSE INDEX OF SPECIFICATIONS AND STANDARDS (DoDiss) SPECIFIED IN THE SOLICITATION FORM A PART OF THIS STANDARD TO THE EXTENT SPECIFIED HEREIN.

(E) DENOTES CHANGES

USER SYMBOLS:
ARMY ER, MI, AT, ME

REVIEWER SYMBOLS:
NAVY AS
USAF 11, 02
ARMY AV
DLA IS

"Review/user information is current as of the date of this document. For future coordination of changes to this document, draft circulation should be based on the information in the current DoDiss."

DISTRIBUTION STATEMENT A. APPROVED FOR PUBLIC RELEASE. DISTRIBUTION IS UNLIMITED. This military standard is approved for use by all Departments & Agencies of the Department of Defense. Selection for all new engineering and design applications and for repetitive use shall be made from this document.

AMSC N/A

P.A. NAVY - AS Other Cust USAF - 11 ARMY - AV	TITLE	MILITARY STANDARD	
		MS21049	
PROCUREMENT SPECIFICATION MIL-N-25027	SUPERSEDES:	SHEET 1 OF 2	
	NAS681, AN361, AND AN373 IN PART		

APPROVED 12 JUN 64 REVISED (A) 12 FEB 65 (B) 4 NOV 66 (C) 21 DEC 71 (D) 15 MAR 76 (E) 24 SEP 86

INTERCHANGEABILITY RELATIONSHIP: MS 21049 NUTS CAN UNIVERSALLY REPLACE NAS 681, AN 361 AND AN 373 NUTS OF LIKE MATERIAL, THREAD SIZE, PLATING, LUBRICANTS (DRY FILM, OR NON DRY FILM), RIVET SPACING, AND FASTENING METHOD (PLAIN RIVET HOLES, DIMPLED, COUNTERSUNK RIVET HOLES OR PROJECTION WELDING). BUT NAS 681, AN 361, AND AN 373 NUTS CANNOT UNIVERSALLY REPLACE MS 21049 NUTS.

SEE SHEET 2

THREAD SIZE	DASH NUMBERS			
	450°F. NON DRY FILM LUBRICATED		450°F. DRY FILM LUBRICATED	
	PLAIN HOLES	CTSK OR DIMPLED HOLES	PLAIN HOLES	CTSK OR DIMPLED HOLES
.1640-32 UNJC-3B	-08	-08K	L08	L08K
.1900-32 UNJF-3B	-3	-3K	L3	L3K
.2500-28 UNJF-3B	-4	-4K	L4	L4K
.3125-24 UNJF-3B	-5	-5K	L5	L5K

EXAMPLE OF PART NUMBER

MS21049L4K

— NUT DASH NUMBER
— BASIC PART NO.

.2500-28 UNJF-3B NUT, SELF LOCKING, TWO LUG, STEEL, 125 KSI, 450°F., DRY FILM LUBRICATED, WITH COUNTERSUNK OR DIMPLED RIVET HOLES.

INTERCHANGEABILITY TABLE			
INACTIVE FOR DESIGN AND CANCELLED PART NUMBERS			SUBSTITUTIVE PART NUMBERS
AN 361	AN 373	NAS 681	
AN 361 - 832	AN 373 - F832	NAS 681 - X08	MS21049-06
---	- F832A	---	NO SUBS. PART
---	---	- X08K	MS21049-08K
- 832	- F832	- A08	MS21049-L08
---	- F832B	---	NO SUBS. PART
---	---	- A08K	MS21049-L08K
- 1032	- F1032	- X3	MS21049-3
---	- F1032A	---	NO SUBS. PART
- 1032	- F1032	- A3	MS21049-L3
---	- F1032B	---	NO SUBS. PART
---	---	- A3K	MS21049-L3K
- 428	- F428	- X4	MS21049-4
---	- F428A	---	NO SUBS. PART
---	---	- X4K	MS21049-4K
- 428	- F428	- A4	MS21049-L4
---	- F428B	---	NO SUBS. PART
---	---	- A4K	MS21049-L4K
---	---	- X3K	MS21049-3K
- 524	- F524	- X5	MS21049-5
---	- F524A	---	NO SUBS. PART
---	---	- X5K	MS21049-5K
- 524	- F524	- A5	MS21049-L5
---	- F524B	---	NO SUBS. PART
AN 361 ---	AN 373 ---	NAS681 - A5K	MS21049-L5K

USER SYMBOLS
ARMY - ER, MI, AT, ME
REVIEWER SYMBOLS:
NAVY - AS
AIR FORCE - II, R 2
ARMY - AV
DLA - IS

"Review/user information is current as of the date of this document. For future coordination of changes in this document, air circulation should be based on the information in the current DODISS."

DISTRIBUTION STATEMENT A: APPROVED FOR PUBLIC RELEASE. DISTRIBUTION IS UNLIMITED. This military standard is approved for use by all Departments & Agencies of the Department of Defense. Selection for all new engineering and design applications and for repetitive use shall be made from this document.

AMSC N/A

P.A. NAVY - AS Other Cust USAF - 11 ARMY - AV	TITLE NUT, SELF-LOCKING, PLATE, TWO LUG, 100° CSK LOW HEIGHT, STEEL, 125 KSI FtU, 450°F	MILITARY STANDARD MS21049
PROCUREMENT SPECIFICATION MIL-N-25027	SUPERSEDES: NAS681, AN361 AND AN373 IN PART	SHEET 2 OF 2

APPROVED 12 JUNE 1964 REVISED (E) FOR CHANGES SEE SHEETS 1 AND 2