

JUL 1 1991
2

REVIEWER SYMBOLS:
ARMY - AR
AIR FORCE - 82
DLA - 15

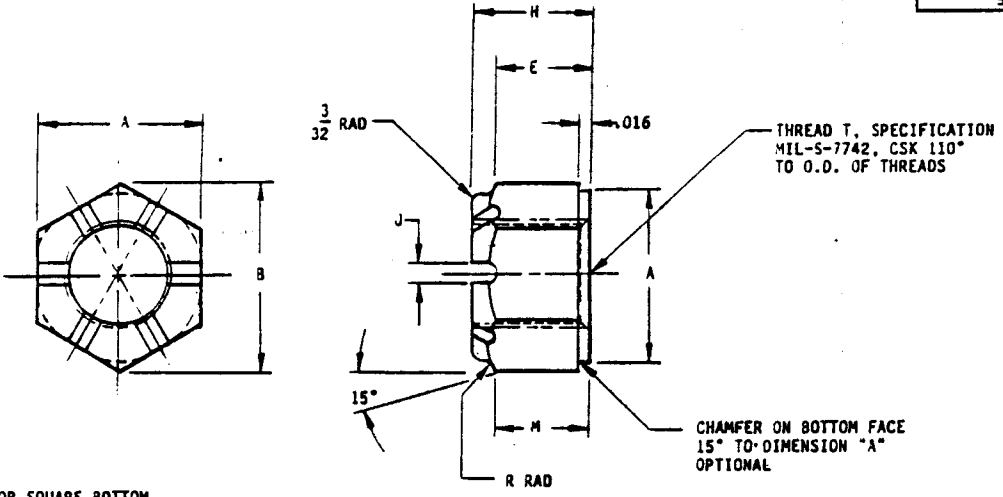

ROUND OR SQUARE BOTTOM
CASTELLATION OPTIONAL

AN PART NO.	THREAD T	ULTIMATE TENSILE STRENGTH MINIMUM POUNDS		(a)						
		STEEL	AL ALLOY	A ⑩	B APPROX	E	H	J +1/32 -0	M	R
AN310-3	NO. 10-32UNF-3B	2,210	1,100	.375 +.002 -.010	7/16	7/64	1/4	5/64	.110	3/32
AN310-4	1/4 -28UNF-3B	4,080	2,030	.438 +.002 -.010	1/2	1/8	9/32	5/64	.125	3/32
AN310-5	5/16 -24UNF-3B	6,500	3,220	.500 +.002 -.010	37/64	11/64	21/64	5/64	.172	3/32
AN310-6	3/8 -24UNF-3B	10,100	5,020	.563 +.002 -.010	21/32	7/32	13/32	1/8	.218	3/32
AN310-7	7/16 -20UNF-3B	13,600	6,750	.625 +.002 -.011	23/32	17/64	29/64	1/8	.265	3/32
AN310-8	1/2 -20UNF-3B	18,500	9,180	.750 +.002 -.012	7/8	23/64	9/16	1/8	.359	1/8
AN310-9	9/16 -18UNF-3B	23,600	11,700	.875 +.002 -.012	1- 1/64	25/64	39/64	5/32	.390	5/32
AN310-10	5/8 -18UNF-3B	30,100	14,900	1.000 +.002 -.014	1- 5/32	15/32	23/32	5/32	.468	5/32
AN310-12	3/4 -16UNF-3B	44,000	21,800	1.125 +.002 -.016	1-19/64	9/16	13/16	5/32	.562	3/16
AN310-14	7/8 -14UNF-3B	60,000	29,800	1.313 +.002 -.017	1-33/64	21/32	29/32	5/32	.656	3/16
AN310-15	1 -12UNF-3B	80,700	40,000	1.500 +.002 -.019	1-47/64	3/4	1	5/32	.750	3/16
(b) AN310-16	1 -14NF-3	80,700	40,000	1.500 +.002 -.019	1-47/64	3/4	1	5/32	.750	3/16
AN310-18	1-1/8-12UNF-3B	101,800	50,500	1.688 +.002 -.021	1-61/64	13/16	1-5/32	5/32	.844	1/4
AN310-20	1-1/4-12UNF-3B	130,200	64,400	1.875 +.002 -.023	2-11/64	7/8	1-1/4	5/32	.938	1/4

- (a) FOR ALUMINUM ALLOY NUTS LARGER THAN -5 SIZE, TOLERANCES ON DIMENSION "A" MAY CONFORM TO APPLICABLE MATERIAL SPECIFICATIONS FOR BAR AND ROD.
- (b) 1-14NF THREAD SIZE INACTIVE FOR DESIGN AFTER 27 MARCH 1967.

⑩ FOR CHANGES, SEE PAGE 1

NOTE: When Government drawings, specifications or other data are used for any purpose other than in connection with a definitely related Government procurement operation, the United States Government thereby incurs no obligation, and the manufacturer, distributor, or other person, by accepting or otherwise using the same, shall be deemed to have accepted the same in any manner, including the making of any other person or corporation, or conveying any rights of manufacture, use, or sell any patented invention that may in any way be related thereto.

DISTRIBUTION STATEMENT A: Approved for public release; distribution is unlimited.
NOTE: This drawing was approved by joint action of the Air Force and Navy Departments at the Air Force - Navy Standard for this product. This drawing conforms to all pertinent standard drawings for the same product and shall become effective for the procurement of aeronautical supplies, or for use in new design not later than 6 months after the latest date of approval shown.
ANSC N/A

P.A. NAVY - AS CUSTODIANS: ARMY - AV NAVY - AS AIR FORCE - 99	AIRFORCE NAVY AERONAUTICAL STANDARD	AN 310
	NUT, PLAIN, CASTELLATED, AIRFRAME	
PROCUREMENT SPECIFICATION FF-N-836	SUPERSEDES: AN385	SHEET 1 OF 2

APPROVED 5 JUL 43 REVISED 8 29 DEC 72 9 25 FEB 91 ⑩ 17 MAY 91

REVIEWER SYMBOLS:
ARMY - AR
AIR FORCE - AF
DLA - JS

NOTES:

1. MATERIAL: STEEL, ALUMINUM ALLOY AND 300 SERIES CORROSION-RESISTANT STEEL. SEE PROCUREMENT SPECIFICATION. (400 SERIES CRES INACTIVE FOR DESIGN AFTER 1 JAN 1992).
2. FINISH: STEEL-CADMIUM PLATING PER QQ-P-416, TYPE II, CLASS 2. PARTS WITH CLASS 3 PLATING MAY BE FURNISHED FROM SUPPLIER'S STOCK UNTIL 1 JANUARY 1975. ALUMINUM ALLOY-ANODIZE IN ACCORDANCE WITH MIL-A-8625, TYPE II. CORROSION RESISTANT STEEL-PASSIVATE IN ACCORDANCE WITH QQ-P-35.
3. DIMENSIONS IN INCHES. UNLESS OTHERWISE SPECIFIED, TOLERANCES: FRACTIONS $\pm 1/64$, DECIMALS $\pm .010$, ANGLES $\pm 1^\circ$.
4. REMOVE ALL BURRS.
5. EXAMPLES OF PART NUMBERS: AN310-5 = STEEL NUT, 5/16-24 UNF-3B.
AN310D5 = ALUMINUM ALLOY NUT, 5/16-24UNF-3B.
AN310C5 = CORROSION-RESISTANT STEEL NUT, 5/16-24UNF-3B.
6. ADD D BEFORE DASH NUMBER FOR ALUMINUM ALLOY NUTS.
ADD C BEFORE DASH NUMBER FOR CORROSION-RESISTANT STEEL NUTS.
7. IN THE EVENT OF A CONFLICT BETWEEN THE TEXT OF THIS STANDARD AND THE REFERENCES CITED HEREIN, THE TEXT OF THIS STANDARD SHALL TAKE PRECEDENCE.
8. REFERENCED GOVERNMENT (OR NON-GOVERNMENT) DOCUMENTS OF THIS ISSUE LISTED IN THAT ISSUE OF THE DEPARTMENT OF DEFENSE INDEX OF SPECIFICATIONS AND STANDARDS (DODISS) SPECIFIED IN THE SOLICITATION FORM A PART OF THIS STANDARD TO THE EXTENT SPECIFIED HEREIN.

INTERCHANGEABILITY RELATIONSHIP: AN310 NUTS ARE UNIVERSALLY INTERCHANGEABLE WITH AN355 NUTS. AN355 NUTS ARE NOT INTERCHANGEABLE WITH AN310 NUTS.

INTERCHANGEABILITY TABLE	
CANCELLED	UNIVERSALLY INTERCHANGEABLE
AN355-3	AN310-3
AN355-4	AN310-4
AN355-5	AN310-5
AN355-6	AN310-6
AN355-7	AN310-7
AN355-8	AN310-8
AN355-9	AN310-9
AN355-10	AN310-10
AN355-12	AN310-12

NOTICE: When Government drawings, specifications or other data are used for any purpose other than in connection with a definitely related Government procurement operation, the United States Government thereby incurs no responsibility, nor any obligation whatsoever, and the fact that the Government may have furnished, furnished, or in any way supplied the data does not constitute an acknowledgment of any right or privilege of copying or otherwise to manufacturers, vendors, or any other person or corporation that may, in any way be related thereto.

QUALITY CONTROL: Approved for public release; distribution is unlimited.
This drawing was prepared by joint action of the Air Force and Army Requirements at the Air Force - Navy standards for this product. This drawing is the standard drawing for the same product and shall be used for the production of this product. The drawing shall be in effect until it is replaced by a new drawing after the latest date of approval shown.
AMSC N/A

APPROVED 5 JUL 43 REVISED (B) 29 DEC 72 (9) 25 FEB 91 (10) 17 MAY 91

P.A. NAVY - AS CUSTODIANS: ARMY - AV NAVY - AS AIR FORCE - 99 PROCUREMENT SPECIFICATION FF-N-836	AIRFORCE NAVY AERONAUTICAL STANDARD	AN310
	NUT, PLAIN, CASTELLATED, AIRFRAME	
SUPERSEDES: AN355	SHEET 2 OF 2	