

JUN 25 1966

4

FED. SUP CLASS
5306

REVIEWER SYMBOLS:
ARMY - AR
USAF - 82
DLA - IS

NOTICE: When Government drawings, specifications or other data are used for any purpose other than in connection with a definitely related Government procurement operation, the United States Government incurs no responsibility, nor any obligation whatsoever; and the fact that the Government may have furnished, furnished, or in any way supplied the said drawings, specifications, or other data is not to be regarded by implication or otherwise as in any manner licensing the holder or any other person or corporation, or conveying any rights or permission to manufacture, use, or sell any patented invention that may in any way be related thereto.

DISTRIBUTION STATEMENT A: APPROVED FOR PUBLIC RELEASE. DISTRIBUTION IS UNLIMITED.
NOTE: This drawing was approved by joint action of the Air Force and Navy Departments as the Air Force-Navy standard for this product. This drawing supersedes all antecedent standard drawings for the same product and shall become effective for the procurement of aeronautical supplies or for use in new design not later than 6 months after the latest date of approval shown.
AMSC N/A

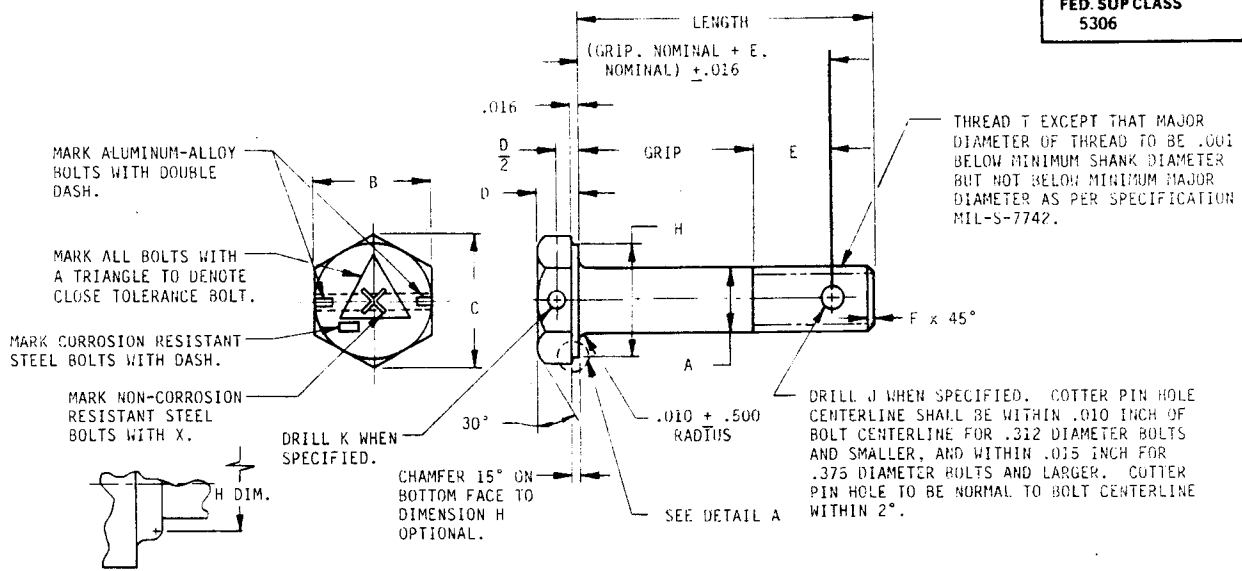

DETAIL A

TABLE I

BASIC AN PART NO.	THREAD T	A DIA		B (b)		C REF	D		E REF	F		H DIA (b)	J DRILL DIA +.010 - .000	K DRILL DIA +.010 - .000
		MAX	MIN	MAX	MIN		MAX	MIN		MAX	MIN			
AN173	.1900-32 NF-3A	.1894	.1889	.377	.365	.430	.141	.109	.266	.047	.015	.335	.070	.046
AN174	.2500-28 UNF-3A	.2492	.2487	.440	.428	.510	.172	.140	.312	.047	.015	.398	.076	.046
AN175	.3125-24 UNF-3A	.3117	.3112	.502	.490	.580	.204	.172	.359	.063	.031	.460	.076	.070
AN176	.3750-24 UNF-3A	.3742	.3737	.565	.553	.650	.235	.203	.438	.063	.031	.523	.106	.070
AN177	.4375-20 UNF-3A	.4367	.4362	.627	.615	.720	.266	.234	.484	.063	.031	.585	.106	.070
AN178	.5000-20 UNF-3A	.4991	.4986	.752	.740	.870	.297	.265	.608	.063	.031	.710	.106	.070
AN179	.5625-18 UNF-3A	.5616	.5611	.877	.865	1.010	.328	.296	.656	.078	.046	.835	.141	.070
AN180	.6250-18 UNF-3A	.6240	.6234	.940	.928	1.090	.360	.328	.734	.078	.046	.898	.141	.070
AN182	.7500-16 UNF-3A	.7488	.7481	1.066	1.053	1.230	.422	.390	.875	.078	.046	1.023	.141	.070
AN184	.8750-14 UNF-3A	.8737	.8729	1.253	1.240	1.440	.485	.453	.984	.094	.062	1.210	.141	.070
AN185	1.000-12 UNF-3A	.9985	.9975	1.441	1.428	1.660	.547	.515	1.031	.094	.062	1.398	.141	.070
AN186	1.000-14 NF-3A	.9985	.9975	1.441	1.428	1.660	.547	.515	1.031	.094	.062	1.398	.141	.070

TABLE I: CONT'D

BASIC AN PART NO.	RATED STRENGTH (POUNDS)					
	ULTIMATE TENSILE AT ROOT DIA		YIELD TENSILE AT ROOT DIA		SINGLE SHEAR AT FULL DIA	
	STEEL	AL ALLOY	STEEL	AL ALLOY	STEEL	AL ALLOY
AN173	2 210	1 100	1 690	710	2 125	990
AN174	4 080	2 030	3 130	1 310	3 680	1 715
AN175	6 500	3 220	4 980	2 080	5 750	2 685
AN176	10 100	5 020	7 740	3 240	8 280	3 870
AN177	13 600	6 750	10 430	4 350	11 250	5 250
AN178	18 500	9 180	14 190	5 920	14 700	6 850
AN179	23 600	11 700	18 100	7 550	18 700	8 700
AN180	30 100	14 900	23 080	9 610	23 000	10 750
AN182	44 000	21 800	33 730	14 100	33 150	15 500
AN184	60 000	29 800	46 000	19 200	45 050	21 050
AN185	80 700	40 000	61 870	25 800	58 900	27 500
AN186	80 700	40 000	61 870	25 800	58 900	27 500

- (a) INACTIVE FOR DESIGN AFTER 21 JUNE 66.
- (b) THE DIAMETER OF THE WASHER FACE SHALL NOT EXCEED THE ACTUAL WIDTH ACROSS THE FLATS.

⑦ INDICATES REVISION

P.A. NAVY - AS Other Cust NAVY - AS USAF - 99 ARMY - AV	AIR FORCE - NAVY AERONAUTICAL STANDARD	AN173 THRU AN186
	BOLT-MACHINE, CLOSE TOLERANCE, AIRCRAFT	
PROCUREMENT SPECIFICATION MIL-B-6812	SUPERSEDES: USAF DRAWINGS 83 THROUGH 96 AND NAS DRAWINGS 53 THROUGH 66	SHEET 1 OF 4

APPROVED 29 MAR 49 REVISED ⑦ 09 APR 90

AMC-9-2

REQUIREMENTS:

- MATERIAL:** NON-CORROSION-RESISTANT STEEL, CORROSION-RESISTANT STEEL, OR ALUMINUM ALLOY. SEE PROCUREMENT SPECIFICATION. CORROSION-RESISTING STEEL BOLTS AND ALUMINUM ALLOY BOLTS INACTIVE FOR DESIGN AFTER 24 MARCH 1952.
- FINISH:** PER MIL-B-6812, EXCEPT PARTS SHALL BE CADMIUM PLATED PER QQ-P-416, TYPE II, CLASS 3. DIMENSIONS SHALL BE MET AFTER PLATING. PARTS PER REV. 5 CAN BE SUPPLIED UNTIL DECEMBER 1989. SURFACE ROUGHNESS IN RMS MICRO INCHES BEFORE PLATING SHALL BE: 63 MAX FOR SHANK AND UNDERSIDE OF HEAD, 125 MAX FOR THREADS (VISUAL COMPARISON ONLY), 250 MAX FOR ALL OTHER AREAS (VISUAL COMPARISON ONLY).

NOTES:

- DIMENSIONS ARE IN INCHES, UNLESS OTHERWISE SPECIFIED, TOLERANCE: DECIMALS $\pm .010$, ANGLES $\pm 5^\circ$.
- REMOVE ALL BURRS AND SLIVERS.
- MARKING MAY BE EITHER RAISED OR DEPRESSED. THE HEIGHT OR DEPTH OF THE MARKINGS SHALL NOT EXCEED THE FOLLOWING VALUES:
 .025 INCH FOR .562 DIAMETER BOLTS AND SMALLER.
 .030 INCH FOR .625 DIAMETER BOLTS AND LARGER.
- GRIP LENGTH OF BOLTS SHALL BE MEASURED FROM THE UNDERSIDE OF THE HEAD TO THE END OF THE FULL CYLINDRICAL PORTION OF THE SHANK. COMPLETE THREADS SHALL BEGIN WITHIN TWO THREAD PITCH MAXIMUM. TWO THREAD PITCH MAXIMUM MAY CONSIST OF INCOMPLETE THREAD OR EXTRUSION ANGLE.
- COUNTERSINKING OF DRILLED HOLES IN HEAD IS MANDATORY. COUNTERSINKING OF DRILL HOLES IN SHANK IS OPTIONAL.
- ADD "C" BEFORE DASH NUMBER FOR CORROSION - RESISTANT STEEL BOLT.
 ADD "DD" BEFORE DASH NUMBER FOR ALUMINUM ALLOY BOLT.
 ADD "A" AFTER DASH NUMBER FOR UNDRILLED BOLT.
 ADD "H" BEFORE DASH NUMBER FOR BOLT WITH DRILLED HEAD AND SHANK
 ADD "H" BEFORE DASH NUMBER AND "A" AFTER DASH NUMBER FOR BOLT WITH DRILLED HEAD ONLY.
- EXAMPLES OF PART NUMBERS: AN176-10 = .375 NON-CORROSION-RESISTANT STEEL BOLT 1.078 LONG, .438 GRIP WITH DRILLED SHANK ONLY.
 AN176C10 = .375 CORROSION-RESISTANT STEEL BOLT 1.078 LONG, .438 GRIP WITH DRILLED SHANK ONLY.
 AN176DD10 = .375 ALUMINUM ALLOY BOLT 1.078 LONG, .438 GRIP WITH DRILLED SHANK ONLY.
 AN176DD10A = .375 ALUMINUM ALLOY BOLT 1.078 LONG, .438 GRIP, UNDRILLED SHANK AND HEAD.
 AN176KDDH10 = .375 ALUMINUM ALLOY BOLT 1.078 LONG, .438 GRIP WITH DRILLED HEAD AND SHANK
 AN176DDH10A = .375 ALUMINUM ALLOY BOLT 1.078 LONG, .438 GRIP WITH DRILLED HEAD ONLY.
- IN THE EVENT OF A CONFLICT BETWEEN THE TEXT OF THIS STANDARD AND THE REFERENCES CITED HEREIN, THE TEXT OF THIS STANDARD SHALL TAKE PRECEDENCE.
- REFERENCED GOVERNMENT (OR NON-GOVERNMENT) DOCUMENTS OF THE ISSUE LISTED IN THAT ISSUE OF THE DEPARTMENT OF DEFENSE INDEX OF SPECIFICATIONS AND STANDARDS (DODISS) SPECIFIED IN THE SOLICITATION FORM A PART OF THIS STANDARD TO THE EXTENT SPECIFIED HEREIN.
- FOR DEFINITION AND APPLICATION OF DRAWING STATUS NOTES, SEE ANA BULLETIN NO. 337.

APPROVED 29 MAR 49 REVISED 7 FOR CHANGES SEE SHT 1

REVIEWER SYMBOLS:
 ARMY - AR
 USAF - BS
 DLA - JS

NOTICE: When Government drawings, specifications or other data are used for any purpose other than in connection with a definitely related Government procurement operation, the United States Government thereby incurs no responsibility, nor any obligation whatsoever; and the fact that the Government may have formulated, furnished, or in any way supplied the said drawings, specifications, or other data is not to be regarded by implication or otherwise as in any manner licensing the holder or any other person or corporation, or conveying any rights or permission to manufacture, use, or sell any patented invention that may in any way be related thereto.

DISTRIBUTION STATEMENT: APPROVED FOR PUBLIC RELEASE. DISTRIBUTION IS UNLIMITED.
 NOTE: This drawing was approved by joint action of the Air Force and Navy Departments as the Air Force-Navy standard for this product. This drawing supersedes all antecedent standard drawings for the same product and shall become effective for the procurement of aeronautical supplies, or for use in new design not later than 6 months after the latest date of approval shown.
 ANSC N/A

P.A. NAVY - AS Other Cust NAVY - AS USAF - 99 ARMY - AV	AIR FORCE-NAVY AERONAUTICAL STANDARD	AN173 THRU AN186
	BOLT-MACHINE, CLOSE TOLERANCE, AIRCRAFT	
PROCUREMENT SPECIFICATION MIL-B-6812	SUPERSEDES: USAF DRAWINGS 83 THROUGH 96 AND NAS DRAWINGS 53 THROUGH 66	SHEET 2 OF 4

TABLE II

DASH NO.	AN173		AN174		AN175		AN176		AN177		AN178		AN179	
	GRIP +.016	LENGTH +.031	GRIP +.016	LENGTH +.031	GRIP +.016	LENGTH +.031	GRIP +.016	LENGTH +.031	GRIP +.016	LENGTH +.031	GRIP +.016	LENGTH +.031	GRIP +.016	LENGTH +.031
3	.062	.469	.062	.469	.062	.469								
4	.125	.531	.062	.531	.062	.594								
5	.250	.656	.188	.656	.188	.719	.062	.703	.062	.719				
6	.375	.781	.312	.781	.312	.844	.188	.828	.188	.844	.062	.844	.062	.969
7	.500	.906	.438	.906	.438	.969	.312	.953	.312	.969	.188	.969	.125	1.031
10	.625	1.031	.562	1.031	.562	1.094	.438	1.078	.438	1.094	.312	1.094	.250	1.156
11	.750	1.156	.688	1.156	.688	1.219	.562	1.203	.562	1.219	.438	1.219	.375	1.281
12	.875	1.281	.812	1.281	.812	1.344	.688	1.328	.688	1.344	.562	1.344	.500	1.406
13	1.000	1.406	.938	1.406	.938	1.469	.812	1.453	.812	1.469	.688	1.469	.625	1.531
14	1.125	1.531	1.062	1.531	1.062	1.594	.938	1.578	.938	1.594	.812	1.594	.750	1.656
15	1.250	1.656	1.188	1.656	1.188	1.719	1.062	1.703	1.062	1.719	.938	1.719	.875	1.781
16	1.375	1.781	1.312	1.781	1.312	1.844	1.188	1.828	1.188	1.844	1.062	1.844	1.000	1.906
17	1.500	1.906	1.438	1.906	1.438	1.969	1.312	1.953	1.312	1.969	1.188	1.969	1.125	2.031
20	1.625	2.031	1.562	2.031	1.562	2.094	1.438	2.078	1.438	2.094	1.312	2.094	1.250	2.156
21	1.750	2.156	1.688	2.156	1.688	2.219	1.562	2.203	1.562	2.219	1.438	2.219	1.375	2.281
22	1.875	2.281	1.812	2.281	1.812	2.344	1.688	2.328	1.688	2.344	1.562	2.344	1.500	2.406
23	2.000	2.406	1.938	2.406	1.938	2.469	1.812	2.453	1.812	2.469	1.688	2.469	1.625	2.531
24	2.125	2.531	2.062	2.531	2.062	2.594	1.938	2.578	1.938	2.594	1.812	2.594	1.750	2.656
25	2.250	2.656	2.188	2.656	2.188	2.719	2.062	2.703	2.062	2.719	1.938	2.719	1.875	2.781
26	2.375	2.781	2.312	2.781	2.312	2.844	2.188	2.828	2.188	2.844	2.062	2.844	2.000	2.906
27	2.500	2.906	2.438	2.906	2.438	2.969	2.312	2.953	2.312	2.969	2.188	2.969	2.125	3.031
30	2.625	3.031	2.562	3.031	2.562	3.094	2.438	3.078	2.438	3.094	2.312	3.094	2.250	3.156
31	2.750	3.156	2.688	3.156	2.688	3.219	2.562	3.203	2.562	3.219	2.438	3.219	2.375	3.281
32	2.875	3.281	2.812	3.281	2.812	3.344	2.688	3.328	2.688	3.344	2.562	3.344	2.500	3.406
33	3.000	3.406	2.938	3.406	2.938	3.469	2.812	3.453	2.812	3.469	2.688	3.469	2.625	3.531
34	3.125	3.531	3.062	3.531	3.062	3.594	2.938	3.578	2.938	3.594	2.812	3.594	2.750	3.656
35	3.250	3.656	3.188	3.656	3.188	3.719	3.062	3.703	3.062	3.719	2.938	3.719	2.875	3.781
36	3.375	3.781	3.312	3.781	3.312	3.844	3.188	3.828	3.188	3.844	3.062	3.844	3.000	3.906
37	3.500	3.906	3.438	3.906	3.438	3.969	3.312	3.953	3.312	3.969	3.188	3.969	3.125	4.031
40	3.625	4.031	3.562	4.031	3.562	4.094	3.438	4.078	3.438	4.094	3.312	4.094	3.250	4.156
41	3.750	4.156	3.688	4.156	3.688	4.219	3.562	4.203	3.562	4.219	3.438	4.219	3.375	4.281
42	3.875	4.281	3.812	4.281	3.812	4.344	3.688	4.328	3.688	4.344	3.562	4.344	3.500	4.406
43	4.000	4.406	3.938	4.406	3.938	4.469	3.812	4.453	3.812	4.469	3.688	4.469	3.625	4.531
44	4.125	4.531	4.062	4.531	4.062	4.594	3.938	4.578	3.938	4.594	3.812	4.594	3.750	4.656
45	4.250	4.656	4.188	4.656	4.188	4.719	4.062	4.703	4.062	4.719	3.938	4.719	3.875	4.781
46	4.375	4.781	4.312	4.781	4.312	4.844	4.188	4.828	4.188	4.844	4.062	4.844	4.000	4.906
47	4.500	4.906	4.438	4.906	4.438	4.969	4.312	4.953	4.312	4.969	4.188	4.969	4.125	5.031
50	4.625	5.031	4.562	5.031	4.562	5.094	4.438	5.078	4.438	5.094	4.312	5.094	4.250	5.156
51	4.750	5.156	4.688	5.156	4.688	5.219	4.562	5.203	4.562	5.219	4.438	5.219	4.375	5.281
52	4.875	5.281	4.812	5.281	4.812	5.344	4.688	5.328	4.688	5.344	4.562	5.344	4.500	5.406
53	5.000	5.406	4.938	5.406	4.938	5.469	4.812	5.453	4.812	5.469	4.688	5.469	4.625	5.531
54	5.125	5.531	5.062	5.531	5.062	5.594	4.938	5.578	4.938	5.594	4.812	5.594	4.750	5.656
55	5.250	5.656	5.188	5.656	5.188	5.719	5.062	5.703	5.062	5.719	4.938	5.719	4.875	5.781
56	5.375	5.781	5.312	5.781	5.312	5.844	5.188	5.828	5.188	5.844	5.062	5.844	5.000	5.906
57	5.500	5.906	5.438	5.906	5.438	5.969	5.312	5.953	5.312	5.969	5.188	5.969	5.125	6.031
60	5.625	6.031	5.562	6.031	5.562	6.094	5.438	6.078	5.438	6.094	5.312	6.094	5.250	6.156
61	5.750	6.156	5.688	6.156	5.688	6.219	5.562	6.203	5.562	6.219	5.438	6.219	5.375	6.281
62	5.875	6.281	5.812	6.281	5.812	6.344	5.688	6.328	5.688	6.344	5.562	6.344	5.500	6.406
63	6.000	6.406	5.938	6.406	5.938	6.469	5.812	6.453	5.812	6.469	5.688	6.469	5.625	6.531
64	6.125	6.531	6.062	6.531	6.062	6.594	5.938	6.578	5.938	6.594	5.812	6.594	5.750	6.656
65	6.250	6.656	6.188	6.656	6.188	6.719	6.062	6.703	6.062	6.719	5.938	6.719	5.875	6.781
66	6.375	6.781	6.312	6.781	6.312	6.844	6.188	6.828	6.188	6.844	6.062	6.844	6.000	6.906
67	6.500	6.906	6.438	6.906	6.438	6.969	6.312	6.953	6.312	6.969	6.188	6.969	6.125	7.031
70	6.625	7.031	6.562	7.031	6.562	7.094	6.438	7.078	6.438	7.094	6.312	7.094	6.250	7.156
71	6.750	7.156	6.688	7.156	6.688	7.219	6.562	7.203	6.562	7.219	6.438	7.219	6.375	7.281
72	6.875	7.281	6.812	7.281	6.812	7.344	6.688	7.328	6.688	7.344	6.562	7.344	6.500	7.406
73	7.000	7.406	6.938	7.406	6.938	7.469	6.812	7.453	6.812	7.469	6.688	7.469	6.625	7.531
74	7.125	7.531	7.062	7.531	7.062	7.594	6.938	7.578	6.938	7.594	6.812	7.594	6.750	7.656
75	7.250	7.656	7.188	7.656	7.188	7.719	7.062	7.703	7.062	7.719	6.938	7.719	6.875	7.781
76	7.375	7.781	7.312	7.781	7.312	7.844	7.188	7.828	7.188	7.844	7.062	7.844	7.000	7.906
77	7.500	7.906	7.438	7.906	7.438	7.969	7.312	7.953	7.312	7.969	7.188	7.969	7.125	8.031
80	7.625	8.031	7.562	8.031	7.562	8.094	7.438	8.078	7.438	8.094	7.312	8.094	7.250	8.156
81														
82														
83														
84								8.062	8.703					
85											7.812	8.594		
86											7.938	8.719		
87											8.062	8.844		
											8.188	8.969		

REVIEWER SYMBOLS:
ARMY - AR
USAF - 82
DLA - IS

NOTICE: When Government drawings, specifications or other data are used for any purpose other than in connection with a definitely related Government procurement operation, the United States Government thereby incurs no responsibility, nor any obligation whatsoever; and the fact that the Government may have formulated, furnished, or in any way supplied the said drawings, specifications, or other data is not to be regarded by implication or otherwise as in any manner licensing the holder or any other person or corporation, or conveying any rights or permission to manufacture, use, or sell any patented invention that may in any way be related thereto.

DISTRIBUTION STATEMENT A: APPROVED FOR PUBLIC RELEASE. DISTRIBUTION IS UNLIMITED.
NOTE: This drawing was approved by joint action of the Air Force and Navy Departments as the Air Force-Navy standard for this product. This drawing supersedes all antecedent standard drawings for the same product and shall become effective for the procurement of aeronautical supplies, or for use in new design not later than 6 months after the latest date of approval shown.
AMSC N/A

P.A. NAVY - AS Other Cust NAVY - AS USAF - 99 ARMY - 9V	AIR FORCE-NAVY AERONAUTICAL STANDARD		AN173 THRU AN186
	BOLT-MACHINE, CLOSE TOLERANCE, AIRCRAFT		
PROCUREMENT SPECIFICATION MIL-B-6812	SUPERSEDES:	USAF DRAWINGS 83 THROUGH 96 AND NAS DRAWINGS 53 THROUGH 66	SHEET 3 OF 4

PREVIOUS EDITIONS OF THIS FORM ARE OBSOLETE.

APPROVED 29 MAR 49 REVISED 7 FOR CHANGES SEE SHTS 1

TABLE II (CONT'D)

DASH NO.	AN180		AN182		AN184		AN185		AN186	
	GRIP +.016	LENGTH +.031 -.016	GRIP +.016	LENGTH +.031 -.016	GRIP +.016	LENGTH +.031 -.016	GRIP +.016	LENGTH +.031 .016	GRIP +.016	LENGTH +.031 -.016
7	.062	1.016								
10	.188	1.141	.062	1.156						
11	.312	1.266	.188	1.281	.062	1.312				
12	.438	1.391	.312	1.406	.188	1.438	.125	1.500	.125	1.500
13	.562	1.516	.438	1.531	.312	1.562	.250	1.625	.250	1.625
14	.688	1.641	.562	1.656	.438	1.688	.375	1.750	.375	1.750
15	.812	1.766	.688	1.781	.562	1.812	.500	1.875	.500	1.875
16	.938	1.891	.812	1.906	.688	1.938	.625	2.000	.625	2.000
17	1.062	2.016	.938	2.031	.812	2.062	.750	2.125	.750	2.125
20	1.188	2.141	1.062	2.156	.938	2.188	.875	2.250	.875	2.250
21	1.312	2.266	1.188	2.281	1.062	2.312	1.000	2.375	1.000	2.375
22	1.438	2.391	1.312	2.406	1.188	2.438	1.125	2.500	1.125	2.500
23	1.562	2.516	1.438	2.531	1.312	2.562	1.250	2.625	1.250	2.625
24	1.688	2.641	1.562	2.656	1.438	2.688	1.375	2.750	1.375	2.750
25	1.812	2.766	1.688	2.781	1.562	2.812	1.500	2.875	1.500	2.875
26	1.938	2.891	1.812	2.906	1.688	2.938	1.625	3.000	1.625	3.000
27	2.062	3.016	1.938	3.031	1.812	3.062	1.750	3.125	1.750	3.125
30	2.188	3.141	2.062	3.156	1.938	3.188	1.875	3.250	1.875	3.250
31	2.312	3.266	2.188	3.281	2.062	3.312	2.000	3.375	2.000	3.375
32	2.438	3.391	2.312	3.406	2.188	3.438	2.125	3.500	2.125	3.500
33	2.562	3.516	2.438	3.531	2.312	3.562	2.250	3.625	2.250	3.625
34	2.688	3.641	2.562	3.656	2.438	3.688	2.375	3.750	2.375	3.750
35	2.812	3.766	2.688	3.781	2.562	3.812	2.500	3.875	2.500	3.875
36	2.938	3.891	2.812	3.906	2.688	3.938	2.625	4.000	2.625	4.000
37	3.062	4.016	2.938	4.031	2.812	4.062	2.750	4.125	2.750	4.125
40	3.188	4.141	3.062	4.156	2.938	4.188	2.875	4.250	2.875	4.250
41	3.312	4.266	3.188	4.281	3.062	4.312	3.000	4.375	3.000	4.375
42	3.438	4.391	3.312	4.406	3.188	4.438	3.125	4.500	3.125	4.500
43	3.562	4.516	3.438	4.531	3.312	4.562	3.250	4.625	3.250	4.625
44	3.688	4.641	3.562	4.656	3.438	4.688	3.375	4.750	3.375	4.750
45	3.812	4.766	3.688	4.781	3.562	4.812	3.500	4.875	3.500	4.875
46	3.938	4.891	3.812	4.906	3.688	4.938	3.625	5.000	3.625	5.000
47	4.062	5.016	3.938	5.031	3.812	5.062	3.750	5.125	3.750	5.125
50	4.188	5.141	4.062	5.156	3.938	5.188	3.875	5.250	3.875	5.250
51	4.312	5.266	4.188	5.281	4.062	5.312	4.000	5.375	4.000	5.375
52	4.438	5.391	4.312	5.406	4.188	5.438	4.125	5.500	4.125	5.500
53	4.562	5.516	4.438	5.531	4.312	5.562	4.250	5.625	4.250	5.625
54	4.688	5.641	4.562	5.656	4.438	5.688	4.375	5.750	4.375	5.750
55	4.812	5.766	4.688	5.781	4.562	5.812	4.500	5.875	4.500	5.875
56	4.938	5.891	4.812	5.906	4.688	5.938	4.625	6.000	4.625	6.000
57	5.062	6.016	4.938	6.031	4.812	6.062	4.750	6.125	4.750	6.125
60	5.188	6.141	5.062	6.156	4.938	6.188	4.875	6.250	4.875	6.250
61	5.312	6.266	5.188	6.281	5.062	6.312	5.000	6.375	5.000	6.375
62	5.438	6.391	5.312	6.406	5.188	6.438	5.125	6.500	5.125	6.500
63	5.562	6.516	5.438	6.531	5.312	6.562	5.250	6.625	5.250	6.625
64	5.688	6.641	5.562	6.656	5.438	6.688	5.375	6.750	5.375	6.750
65	5.812	6.766	5.688	6.781	5.562	6.812	5.500	6.875	5.500	6.875
66	5.938	6.891	5.812	6.906	5.688	6.938	5.625	7.000	5.625	7.000
67	6.062	7.016	5.938	7.031	5.812	7.062	5.750	7.125	5.750	7.125
70	6.188	7.141	6.062	7.156	5.938	7.188	5.875	7.250	5.875	7.250
71	6.312	7.266	6.188	7.281	6.062	7.312	6.000	7.375	6.000	7.375
72	6.438	7.391	6.312	7.406	6.188	7.438	6.125	7.500	6.125	7.500
73	6.562	7.516	6.438	7.531	6.312	7.562	6.250	7.625	6.250	7.625
74	6.688	7.641	6.562	7.656	6.438	7.688	6.375	7.750	6.375	7.750
75	6.812	7.766	6.688	7.781	6.562	7.812	6.500	7.875	6.500	7.875
76	6.938	7.891	6.812	7.906	6.688	7.938	6.625	8.000	6.625	8.000
77	7.062	8.016	6.938	8.031	6.812	8.062	6.750	8.125	6.750	8.125
80	7.188	8.141	7.062	8.156	6.938	8.188	6.875	8.250	6.875	8.250
81							7.000	8.375	7.000	8.375
82							7.125	8.500	7.125	8.500

REVIEWER SYMBOLS:
ARMY - AR
USAF - 82
DLA - IS

NOTICE: When Government drawings, specifications or other data are used for any purpose other than in connection with a definitely related Government procurement operation, the United States Government thereby incurs no responsibility, nor any obligation whatsoever; and the fact that the Government may have furnished, furnished, or in any way supplied the said drawings, specifications, or other data is not to be regarded by implication or otherwise as in any manner licensing the holder or any other person or corporation, or conveying any rights or permission to manufacture, use, or sell any patented invention that may in any way be related thereto.

DISTRIBUTION STATEMENT A. APPROVED FOR PUBLIC RELEASE. DISTRIBUTION IS UNLIMITED.

NOTE: This drawing was approved by joint action of the Air Force and Navy Departments as the Air Force-Navy standard for this product. This drawing supersedes all antecedent standard drawings for the same product and shall become effective for the procurement of aeronautical supplies, or for use in new design not later than 6 months after the latest date of approval shown.

AMSC N/A

APPROVED 29 MAR 49 REVISED 7 FOR CHANGES SEE SITS I

P.A. NAVY - AS Other Cust NAVY - AS USAF - 99 ARMY - AV	AIR FORCE-NAVY AERONAUTICAL STANDARD	ANI73 THRU ANI86
	BOLT-MACHINE, CLOSE TOLERANCE, AIRCRAFT	
PROCUREMENT SPECIFICATION MIL-8-6812	SUPERSEDES: USAF DRAWINGS 83 THROUGH 96 AND NAS DRAWINGS 53 THROUGH 66	SHEET 4 OF 4